



Vibratory Drying Equipment

Since 1965, the founders of CLM VIBETECH, Inc. have produced, serviced, repaired and restored Vibratory Equipment. Drawing on the experience from working on almost every brand of vibratory machines, CLM VIBE TECH Inc. has designed a full line of vibratory equipment using the best features available in today's industry. As a customer said after seeing all the brands in the plant for repair, "Looks like you build the best and fix the rest". That statement is very true. From the inside out our machines are built with experience.



Model VTG-5024D

Model VTG-5024D

Unbeatable Features...

- Our infrared heat system is more economical and efficient than heated oil/water systems.
- Process channel is heated directly from the bottom, distributing heat more evenly than standing heat lamp assemblies.
- All heavy-duty welded construction.
- Load chute, extended internal screen deck and dual heat banks are standard.
- Exterior side walls are insulated for operator safety.
- Cool-down timer allows machine to run while cooling at end of cycle, eliminating scorching and cobb deterioration.
- Less floor space required than competitive models.
- Moveable gate available for longer cycle times.
- Dust covers and dust collectors can be designed for any system.
- We can design our cobb dryers to work "in line" with your existing finishing machines.

Designed better to last longer...

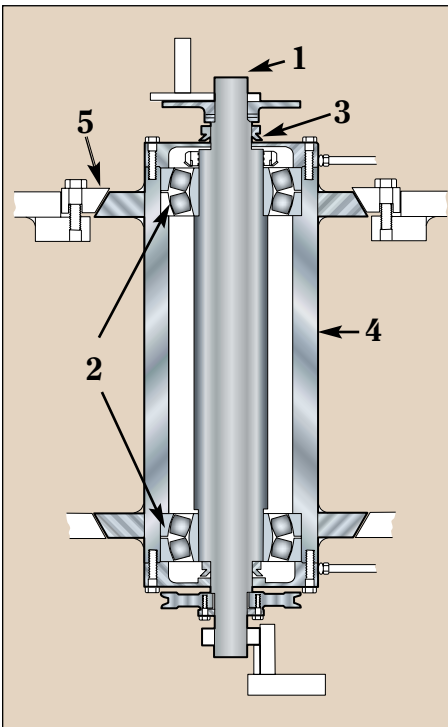

The heart of our oil lubricated vibratory dryer is the drive cartridge...

1. Heavy-duty, over-sized, precision machined drive shaft.
2. Highest quality double-row spherical bearings are fitted to drive shaft, with clearance to allow for heat expansion, unlike pressed bearings that can build-up heat and reduce bearing life.
3. Lightweight non-abrasive seals will never damage shaft.
4. For service, our extra-heavy walled cartridge is the most easily accessible and removable cartridge in the industry.
5. Tapered drive clips are pulled down with grade 9 bolts, superior to relying on bolt shear strength.

The conical structure and the center tube are designed to optimize the transfer of energy from the drive cartridge to the process channel by distributing it correctly and without unnecessary stress to the structure.

Dryer Options:

- Manual Movable Gates
- Pneumatic Gates • PLC Automation
- Dust covers • Dust collectors
- Rigid Pneumatic sound covers
- Air Knife • Step-down Screens
- Material Handling • Media Classifying
- Shaker Screeners

Accessories for all makes:

- Drains • Gates • Compound System
- Screens • Noise and Dust Covers

Services:

- **Process Evaluation:** send us your sample parts for a free process evaluation.
- **System Design:** we can design and build custom systems from simple batch processes to fully automated systems.
- **Vibratory Equipment Repair:** we service all makes and models of vibratory equipment from basic repair to complete restoration.
- **Relining:** on all makes and models, 3 grades of urethane available from cold to hot pour.

For Service Call... 1-800-741-0670

Specification and Dimensions

Model	VTG-3816D*	VTG-5024D	VT-5024D	VT-5524D	VT-6026D	VT-6830D	VT-7230D	VT-8844D
Capacity (cu. ft.)	5	8.5	8.5	11	15	22	28	41
Motor Hp (A)	3	5	5	7.5	7.5	10	10	20
Load chute (B)	Included	Included	Included	Included	Included	Included	Included	Included
Extended screen (C)	Std	Std	Std	Std.	Std	Std	Std	Std
Lubrication system (D)	Grease	Grease	Auto Oil	Auto Oil	Auto Oil	Auto Oil	Auto Oil	Auto Oil
Load Chute Height (E)	31"	34"	34"	35"	37"	44"	44"	56"
Discharge height (F)	31"	34"	34"	35"	37"	44"	44"	56"
Channel width (G)	11"	13"	13"	15.5"	17"	19"	21"	22"
Overall diameter (H)	38"	50"	50"	55"	60"	68"	72"	88"
Overall height (I)	36"	42"	42"	43"	44"	53"	53"	64"
Foot print	4' x 4'	5' x 5'	5' x 5'	5' x 5'	6' x 6'	7' x 7'	7' x 7'	8' x 8'

Due to on going design improvements, design and specifications are subject to change without notice.

In addition to our line of Dryers we have a full line of: **Vibratory Finishers**, **Vibratory Combos**; Finisher/Dryer, **Long Radius Finishers**; for excellent steel ball burnishing and longer cycle times, can be set up for continuous operations, **Helix Finishers**; for continuous operations, **Tub Finishers**; for batch processes

* Single heat bank system

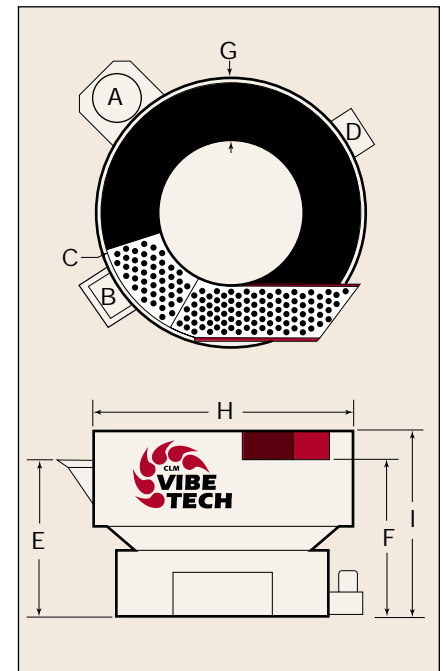

Distributed by:



7025 East K Avenue
Kalamazoo, Michigan 49048
Ph: 269-344-3878 Fax: 269-344-3088